



O P . / -

KN AN= HA ARE A	L= G=CEJC PULA	OP= J =N L= GMPU	L= G=CA I =NGEJC	LEJO	L= G=CA AO NÆPKJ	I OH
--------------------	-------------------	---------------------	---------------------	------	---------------------	------

J=I A	LEJ	LEJ BQJ PÆJ

L=N=I APAN	ABEJ PÆJ	I EJ	I =T	QJÆ

L=N=I APAN	ABEJ PÆJ	I EJ	I =T	QJÆ

O P . / -

OUI KH	L=N=I APAN	PAOP KJ PEKJ	I EJ PUL I =T	QJP
[REDACTED] K				
	[REDACTED]			

B - O P. . / - A (R 9-.R

B . R R REJ

= K)

4

B L S I BLS I

REJ L 4 4

Q R H QRHK

A O 4

4

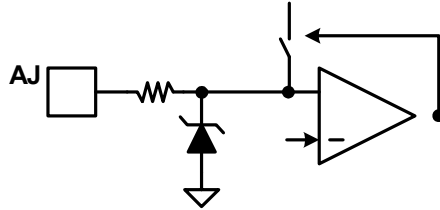

B 3 = REJ QRHK

$$3 = \frac{(\text{---}) -}{1(1 - \text{---}) + 2}$$

4

$$4 = \frac{3 \times}{- + 3(1 + 2)}$$

K L K L D I

R N

O P. . / -

O P.. / -

K B N O

$$1 = \frac{(\quad - \quad) \times 2}{\quad} \quad 4$$

K R R N- P . N O
N. H D - B . B / B

4

4

= S

4

B 5 OS REJ9-. R(KQP9/ = K N

B -, OS S REJ9-. R(KQP9-, = K N

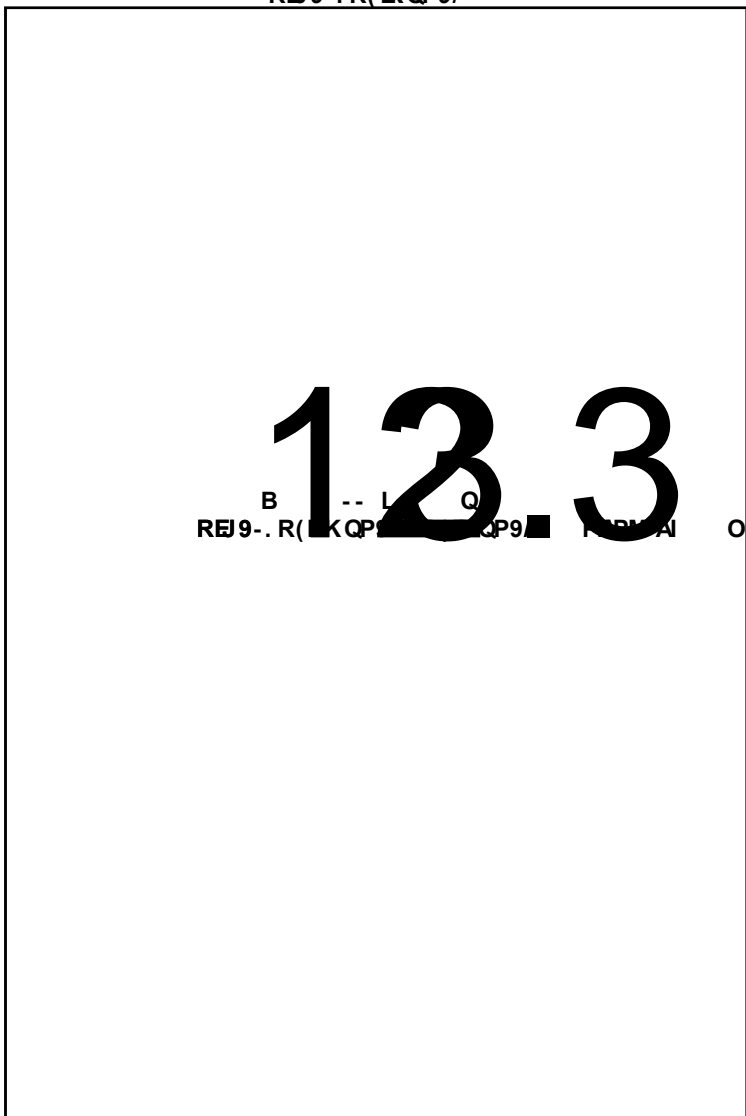

H C

4

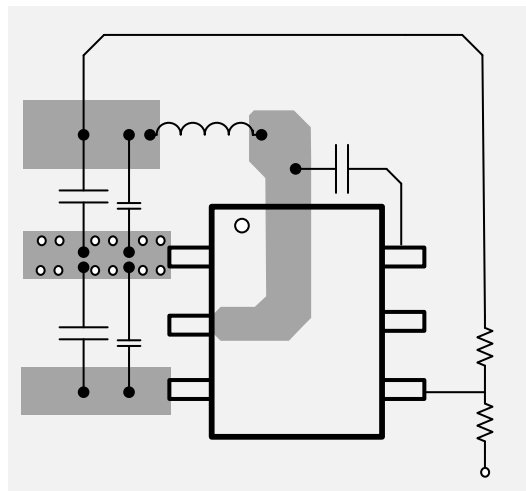

B -1 L H A

4

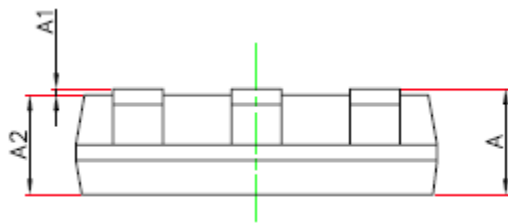
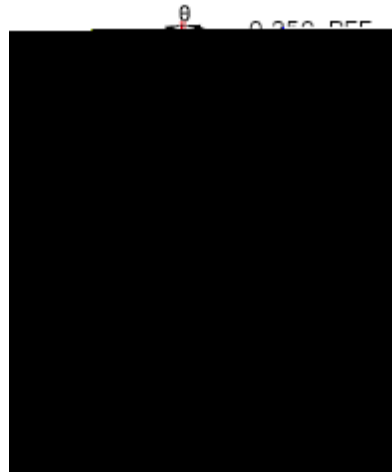
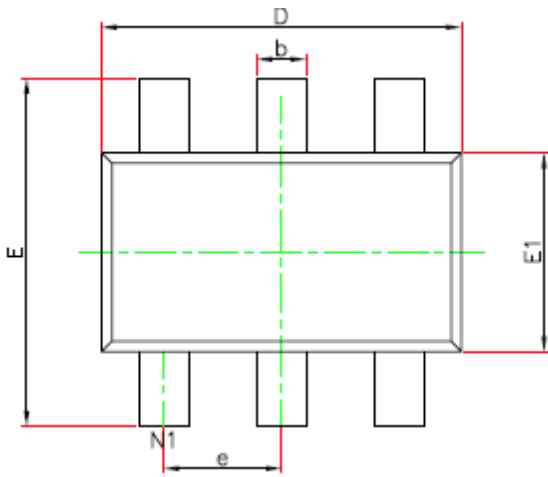

OUI	KH	Q 6I		
		I EJ	PUL	I =T

JKPA6

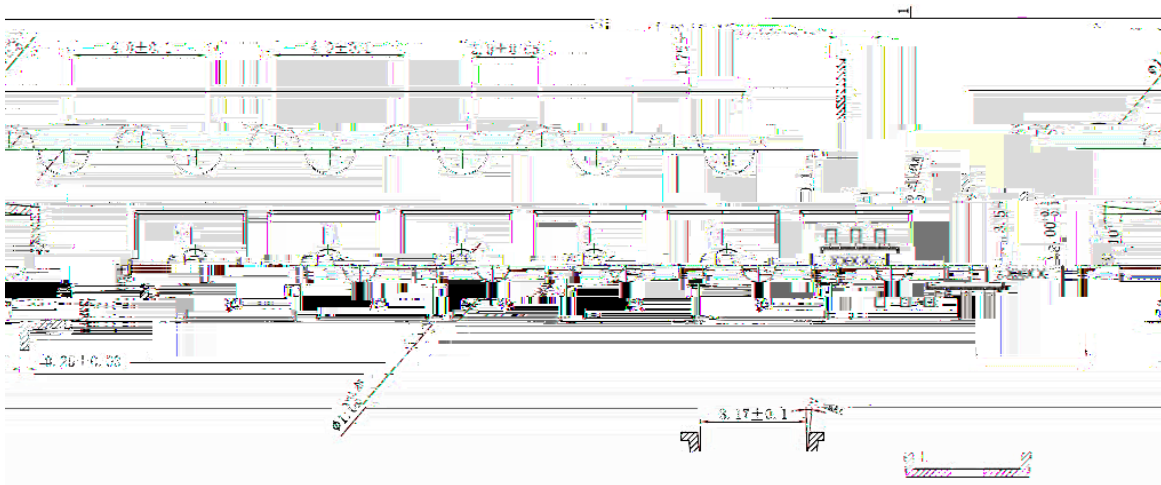
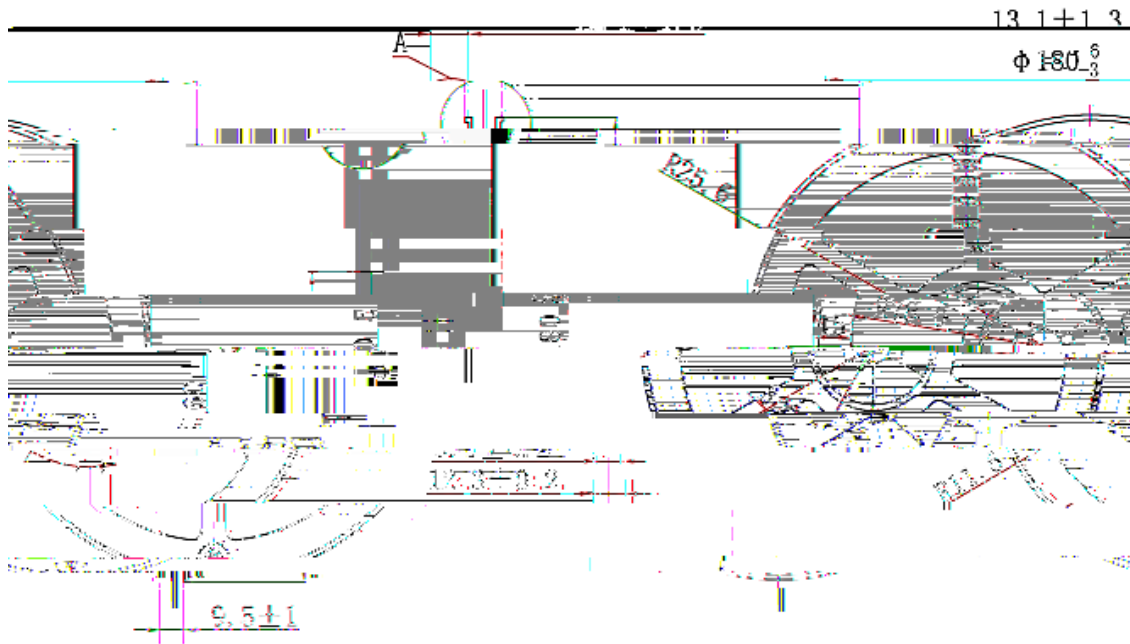

B

